



US 20250293424A1

(19) **United States**

(12) **Patent Application Publication**  
**CHIU et al.**

(10) **Pub. No.: US 2025/0293424 A1**

(43) **Pub. Date: Sep. 18, 2025**

(54) **ELECTRONIC PACKAGE AND  
MANUFACTURING METHOD THEREOF**

*H01L 23/31* (2006.01)

*H01L 23/498* (2006.01)

*H01L 23/538* (2006.01)

(71) Applicant: **SILICONWARE PRECISION  
INDUSTRIES CO., LTD.**, Taichung  
City (TW)

*H01L 23/552* (2006.01)

*H01L 25/16* (2023.01)

*H01Q 9/04* (2006.01)

*H01Q 21/06* (2006.01)

(72) Inventors: **Chih-Hsien CHIU**, Taichung City  
(TW); **Ko-Wei CHANG**, Taichung City  
(TW); **Chia-Chen CHIAO**, Taichung  
City (TW); **Chien-Cheng LIN**,  
Taichung City (TW); **Chun-Sheng  
CHANG**, Taichung City (TW);  
**Wen-Jung TSAI**, Taichung City (TW)

(52) **U.S. Cl.**

CPC ..... *H01Q 1/2283* (2013.01); *H01L 21/4853*

(2013.01); *H01L 23/49811* (2013.01); *H01L*

*23/5385* (2013.01); *H01L 24/16* (2013.01);

*H01L 24/32* (2013.01); *H01L 24/73* (2013.01);

*H01L 25/162* (2013.01); *H01Q 9/0407*

(2013.01); *H01Q 21/065* (2013.01); *H01L*

*23/3107* (2013.01); *H01L 23/552* (2013.01);

*H01L 2224/16227* (2013.01); *H01L*

*2224/32225* (2013.01); *H01L 2224/73253*

(2013.01)

(73) Assignee: **SILICONWARE PRECISION  
INDUSTRIES CO., LTD.**, Taichung  
City (TW)

(21) Appl. No.: **18/910,909**

(57)

**ABSTRACT**

(22) Filed: **Oct. 9, 2024**

An electronic package is provided, which includes: a packaging module having a first side, a second side opposite to the first side, and a first electronic element provided on the first side; an antenna module having a first surface and a second surface opposite to the first surface, wherein the first surface of the antenna module is coupled to the second side of the packaging module via a plurality of conductive elements; and a second electronic element disposed between the second side of the packaging module and the first surface of the antenna module. Also provided is a method of manufacturing the electronic package.

(30) **Foreign Application Priority Data**

Mar. 14, 2024 (TW) ..... 113109519

**Publication Classification**

(51) **Int. Cl.**

*H01Q 1/22* (2006.01)

*H01L 21/48* (2006.01)

*H01L 23/00* (2006.01)

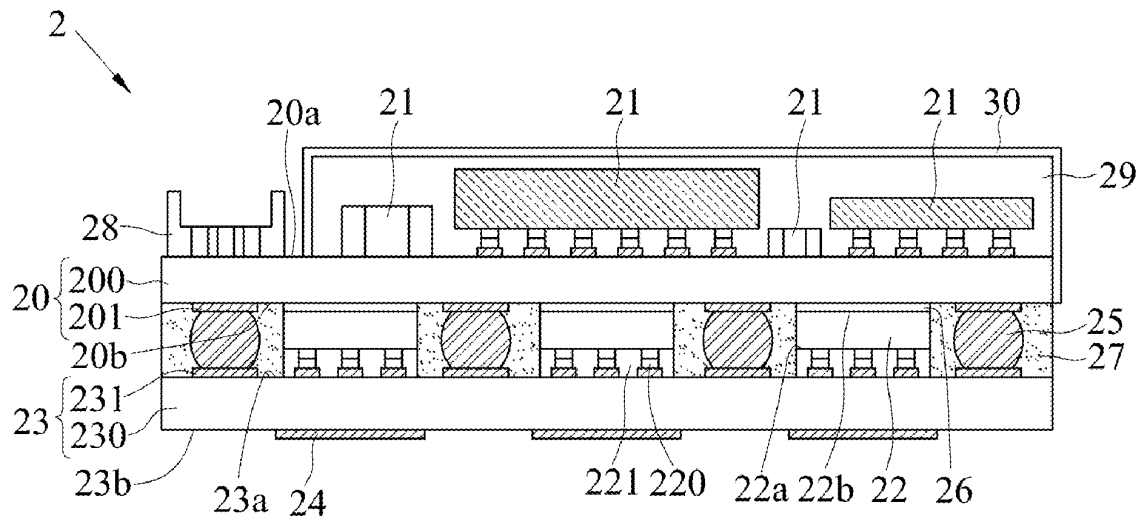



US 20250293427A1

(19) **United States**

(12) **Patent Application Publication**  
**Tang**

(10) **Pub. No.: US 2025/0293427 A1**

(43) **Pub. Date: Sep. 18, 2025**

(54) **THREE-DIMENSIONAL (3D) WIRELESS  
MULTIBAND ANTENNA FOR SECURITY  
GATEWAY**

*H01Q 1/22* (2006.01)

*H01Q 1/24* (2006.01)

(52) **U.S. Cl.**  
CPC ..... *H01Q 1/44* (2013.01); *G08B 3/1016*  
(2013.01); *H01Q 1/2291* (2013.01); *H01Q*  
*1/241* (2013.01)

(71) Applicant: **Lap Tak Tang**, Hong Kong (CN)

(72) Inventor: **Lap Tak Tang**, Hong Kong (CN)

(21) Appl. No.: **19/092,678**

(22) Filed: **Mar. 27, 2025**

(30) **Foreign Application Priority Data**

Mar. 25, 2025 (CN) ..... 202520537069.1

**Publication Classification**

(51) **Int. Cl.**  
*H01Q 1/44* (2006.01)  
*G08B 3/10* (2006.01)

(57) **ABSTRACT**

A three-dimensional (3D) wireless multiband antenna for security gateway, including an antenna carrier assembly, a plurality of 3D antennas and an audio assembly. The plurality of 3D antennas are provided spaced apart on the antenna carrier assembly. The audio assembly is connected with the antenna carrier assembly, and the antenna carrier assembly and the audio assembly enclose a mounting hole. The mounting hole is configured to mount the security gateway.

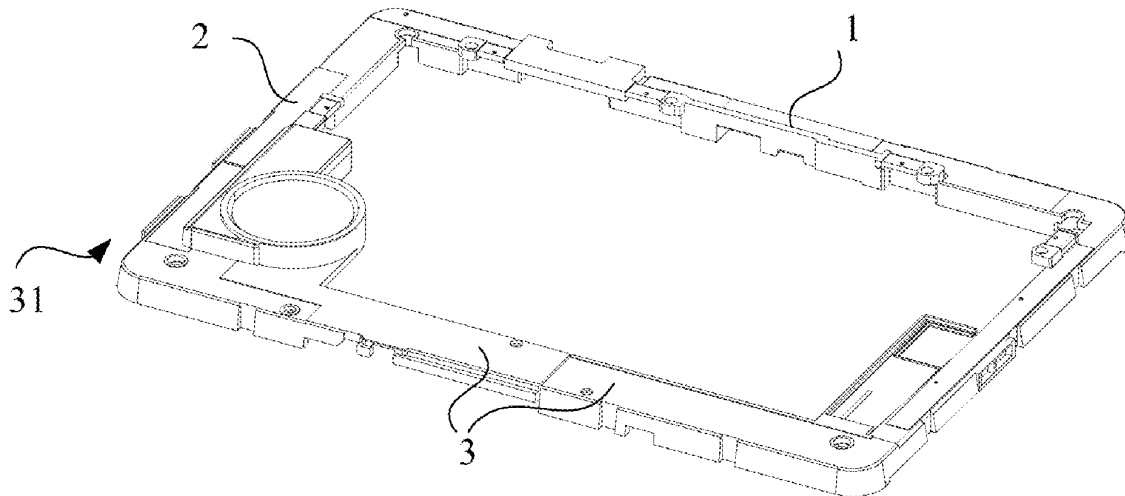



(19) **United States**

(12) **Patent Application Publication** (10) **Pub. No.: US 2025/0293428 A1**  
Sonkki (43) **Pub. Date: Sep. 18, 2025**

(54) **WIDEBAND RADIATOR WITH HIGH ANTENNA PORT ISOLATION**

(52) **U.S. Cl.**  
CPC ..... **H01Q 1/523** (2013.01)

(71) Applicant: **Telefonaktiebolaget LM Ericsson (publ)**, Stockholm (SE)

(57) **ABSTRACT**

(72) Inventor: **Marko Sonkki**, Rosenheim (DE)

A multimode antenna comprising: a conducting body; and a first and a second antenna port, which are respectively adapted for excitation of a first and a second set of radiation modes, all radiation modes sharing a common boundary curve at which an electric boundary condition, EBC, or a magnetic boundary condition, MBC, is satisfied. The first set consists of multiple radiation modes for which the EBC is satisfied at the common boundary curve, and the second set consists of multiple radiation modes for which the MBC is satisfied at the common boundary curve. In an embodiment, the first and second antenna ports are adapted for simultaneous excitation of multiple radiation modes of the first and second sets.

(21) Appl. No.: **18/860,776**

(22) PCT Filed: **Apr. 27, 2022**

(86) PCT No.: **PCT/EP2022/061273**

§ 371 (c)(1),

(2) Date: **Oct. 28, 2024**

**Publication Classification**

(51) **Int. Cl.**  
**H01Q 1/52** (2006.01)

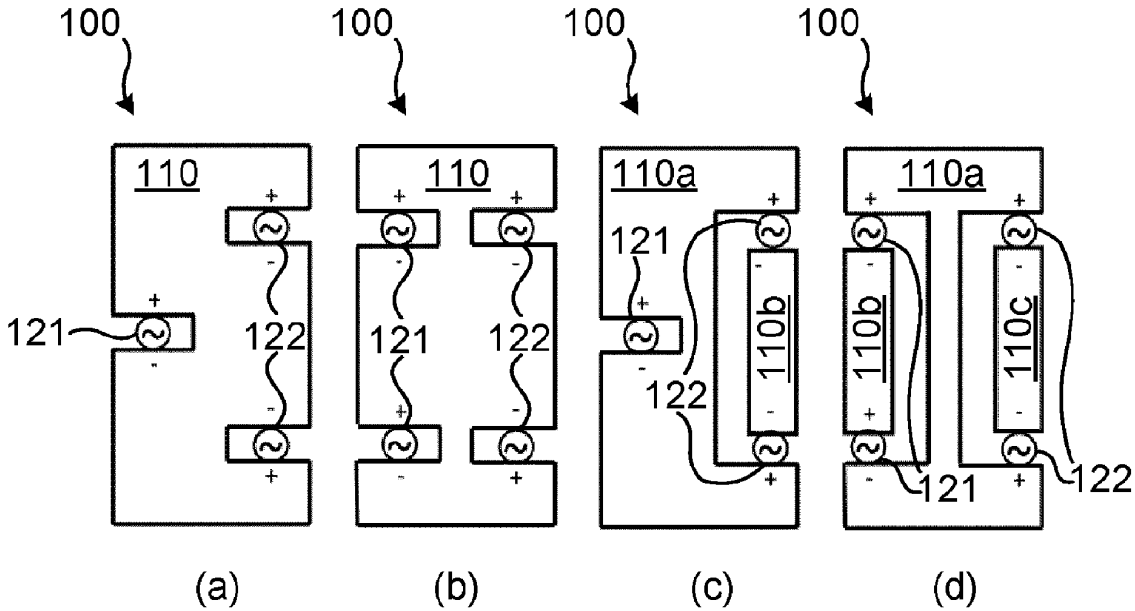



US 20250293432A1

(19) **United States**

(12) **Patent Application Publication**  
**SHI**

(10) **Pub. No.: US 2025/0293432 A1**

(43) **Pub. Date: Sep. 18, 2025**

(54) **CIRCULARLY POLARIZED ANTENNA AND  
DUAL-FREQUENCY CIRCULARLY  
POLARIZED ANTENNA**

(52) **U.S. Cl.**  
CPC ..... **H01Q 5/314** (2015.01); **H01Q 5/10**  
(2015.01); **H01Q 5/28** (2015.01)

(71) Applicant: **GUANGDONG COROS SPORTS  
TECHNOLOGY CO., LTD**, Dongguan  
(CN)

(57) **ABSTRACT**

(72) Inventor: **Xianwei SHI**, Dongguan (CN)

A circularly polarized antenna is provided, including a main board; an annular radiator provided with an access portion; a feeding terminal, one end of the feeding terminal is electrically connected to the radiator at a feeding point, and the other end of the feeding terminal is electrically connected to the main board; a frequency tuning component which is configured to adjust a frequency of the communication frequency band of the circularly polarized antenna, and is electrically connected to the radiator at the access portion. A first connecting line is a line connecting the feeding point and a center point of the annular radiator, a second connecting line is a line connecting the access portion and the center point of the radiator, and the first connecting line and a second connecting line form a first included angle  $\alpha$  along a counterclockwise circumferential direction of the radiator, where,  $\alpha \in (80^\circ, 100^\circ) \cup (170^\circ, 190^\circ) \cup (260^\circ, 280^\circ)$ .

(21) Appl. No.: **19/220,888**

(22) Filed: **May 28, 2025**

**Related U.S. Application Data**

(63) Continuation of application No. PCT/CN2023/107207, filed on Jul. 13, 2023.

**Publication Classification**

(51) **Int. Cl.**  
**H01Q 5/314** (2015.01)  
**H01Q 5/10** (2015.01)  
**H01Q 5/28** (2015.01)

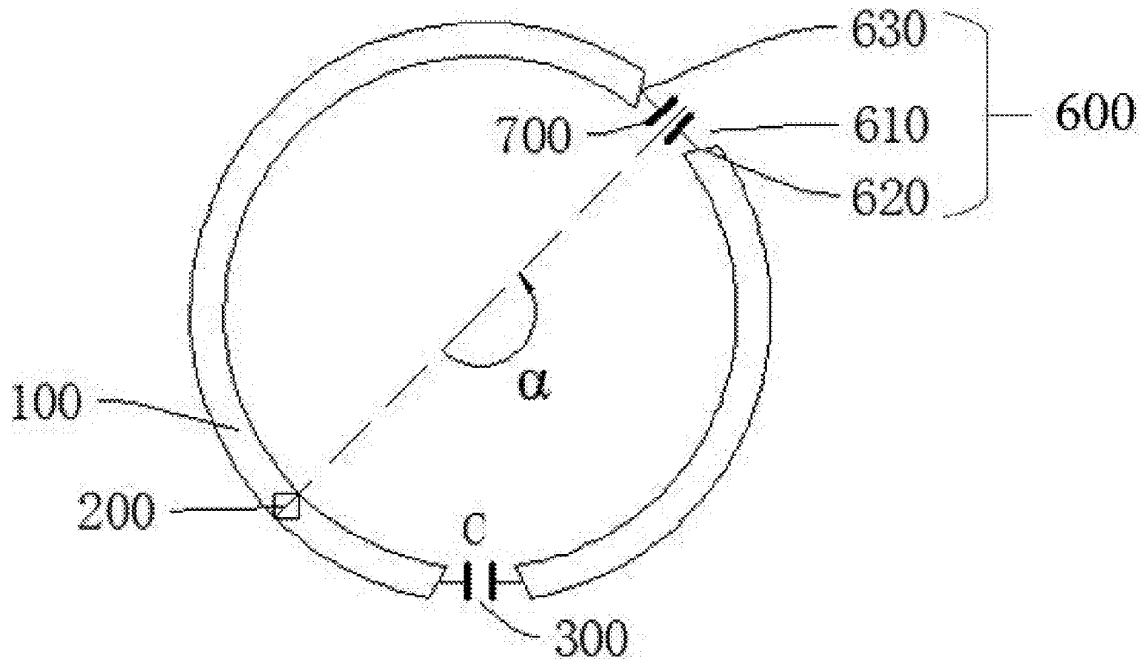



US 20250293434A1

(19) **United States**

(12) **Patent Application Publication**  
**Yang et al.**

(10) **Pub. No.: US 2025/0293434 A1**

(43) **Pub. Date: Sep. 18, 2025**

(54) **ELECTRONIC DEVICE ANTENNAS WITH DISTRIBUTED CAPACITANCES**

(71) Applicant: **Apple Inc.**, Cupertino, CA (US)

(72) Inventors: **Yuechen Yang**, San Jose, CA (US); **Alexandrine Obrand**, Palo Alto, CA (US); **Abhay Shankar Anand**, Santa Clara, CA (US); **Panagiotis Theofanopoulos**, Cupertino, CA (US); **David Garrido Lopez**, San Jose, CA (US); **Xiangyu Wang**, Santa Clara, CA (US); **Kourosh Khanjani**, Los Gatos, CA (US); **Jordi A. Sim**, San Mateo, CA (US); **Matthew Derry**, Mountain View, CA (US); **Subramanian Ramalingam**, San Jose, CA (US); **Jacob T. Ramirez**, Cupertino, CA (US); **Forhad Hasnat**, Milpitas, CA (US); **Ross M. Errett**, San Jose, CA (US); **Zhe Zhang**, Santa Clara, CA (US); **Joseph J Sunde**, Monterey, CA (US)

(21) Appl. No.: **18/805,444**

(22) Filed: **Aug. 14, 2024**

**Related U.S. Application Data**

(60) Provisional application No. 63/565,510, filed on Mar. 14, 2024.

**Publication Classification**

(51) **Int. Cl.**  
**H01Q 13/10** (2006.01)  
**H01Q 5/378** (2015.01)  
(52) **U.S. Cl.**  
CPC ..... **H01Q 13/10** (2013.01); **H01Q 5/378** (2015.01)

(57) **ABSTRACT**

An electronic device may be provided with peripheral conductive housing structures and a rear wall. An antenna may be formed from a segment of the peripheral conductive housing structures that is separated from the rear wall by a slot. One or more distributed capacitors may be used to tune the response of the antenna. The distributed capacitors may be formed between the segment and a parasitic arm shorted to the rear wall, between a protrusion on the segment and the rear wall, and/or a between conductive traces on a flex coupled to a feed of the antenna. The parasitic arm may be formed from conductive traces on a flexible printed circuit, sheet metal, or other conductive material. The protrusion may extend into the slot and may be embedded in dielectric material. The protrusion may include holes that draw in some of the dielectric material to minimize cosmetic defects.

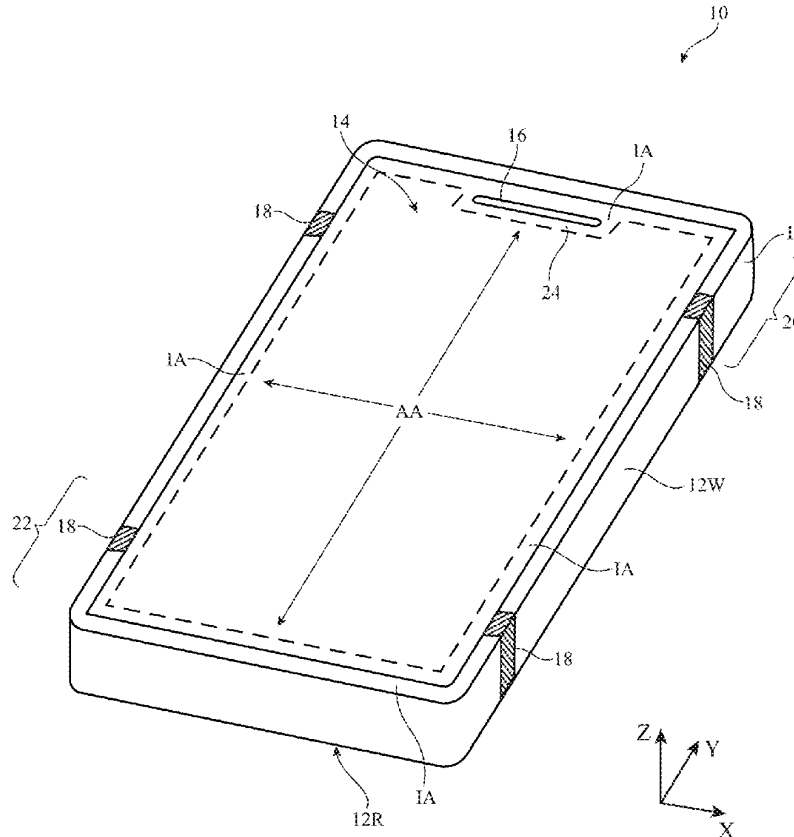



US 20250294388A1

(19) **United States**

(12) **Patent Application Publication**  
**HAKOLA et al.**

(10) **Pub. No.: US 2025/0294388 A1**

(43) **Pub. Date: Sep. 18, 2025**

(54) **CAPABILITY AWARE BEAM REPORTING FOR UPLINK TRANSMISSION**

**Publication Classification**

(71) Applicant: **Nokia Technologies Oy**, Espoo (FI)

(51) **Int. Cl.**  
*H04W 24/08* (2009.01)  
*H04B 17/318* (2015.01)  
*H04L 5/00* (2006.01)  
*H04W 24/10* (2009.01)

(72) Inventors: **Sami-Jukka HAKOLA**, Kempele (FI);  
**Mihai ENESCU**, Espoo (FI); **Keeth Saliya Jayasinghe Saliya Jayasinghe LADDU**, Espoo (FI); **Juha Pekka KARJALAINEN**, Oulu (FI); **Timo KOSKELA**, Oulu (FI)

(52) **U.S. Cl.**  
CPC ..... *H04W 24/08* (2013.01); *H04B 17/328* (2023.05); *H04L 5/0048* (2013.01); *H04W 24/10* (2013.01)

(73) Assignee: **Nokia Technologies Oy**, Espoo (FI)

(57) **ABSTRACT**

(21) Appl. No.: **18/860,821**

Various example embodiments relate to capability aware beam reporting for uplink—UL—transmission. An apparatus may receive, from a network node, a transmission of a plurality of downlink—DL—reference signals—RSs—. The apparatus may measure the DL RSs for at least one capability value set of a user equipment—UE—, each capability value set being associated with a group of one or more antenna ports of the UE. The apparatus may transmit, to the network node, a report identifying one or more DL RS resources and one or more capability value sets.

(22) PCT Filed: **Apr. 29, 2022**

(86) PCT No.: **PCT/EP2022/061572**

§ 371 (c)(1),

(2) Date: **Oct. 28, 2024**

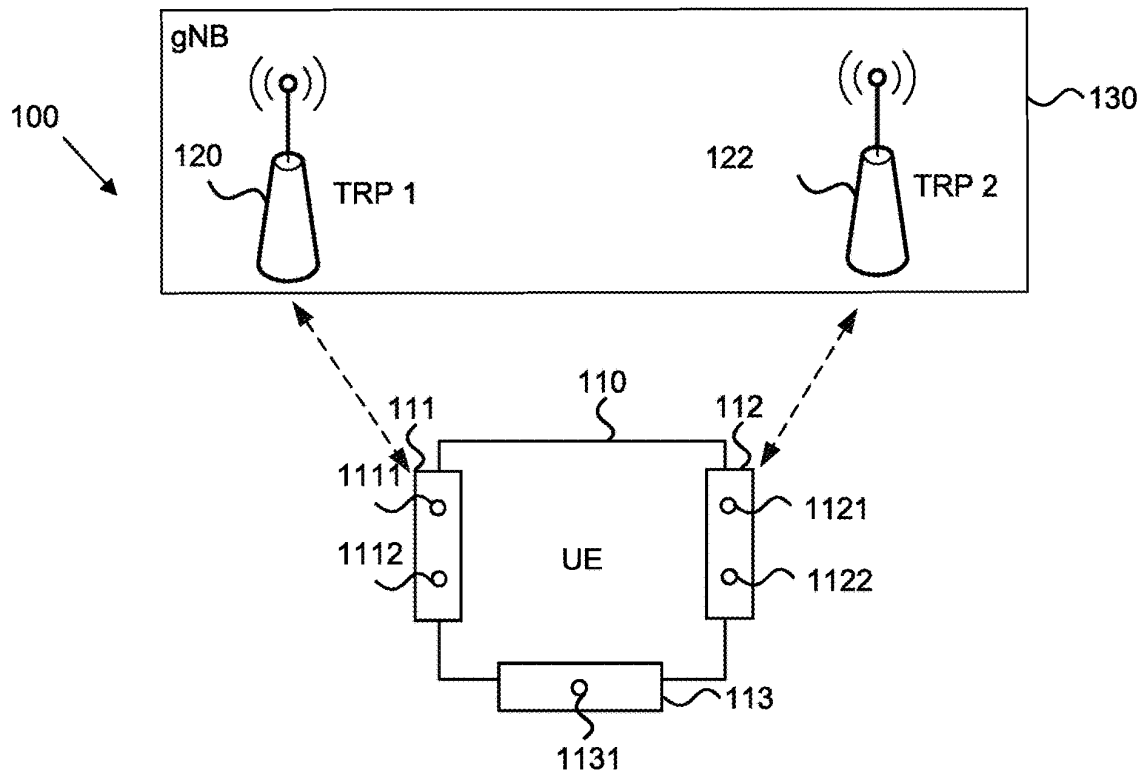



US 20250294573A1

(19) **United States**

(12) **Patent Application Publication**  
**HOSSEINI et al.**

(10) **Pub. No.: US 2025/0294573 A1**

(43) **Pub. Date: Sep. 18, 2025**

(54) **TECHNIQUES FOR RECYCLING ANTENNAS FOR MULTI-COMPONENT CARRIER (CC) OPERATIONS IN WIRELESS COMMUNICATIONS**

**Publication Classification**

(51) **Int. Cl.**  
*H04W 72/231* (2023.01)  
*H04B 7/06* (2006.01)  
*H04L 5/00* (2006.01)  
*H04W 76/20* (2018.01)

(52) **U.S. Cl.**  
 CPC ..... *H04W 72/231* (2023.01); *H04B 7/0626* (2013.01); *H04L 5/0051* (2013.01); *H04W 76/20* (2018.02)

(71) Applicant: **QUALCOMM Incorporated**, San Diego, CA (US)

(72) Inventors: **Kianoush HOSSEINI**, San Diego, CA (US); **Mostafa KHOSHNEVISAN**, San Diego, CA (US); **Kazuki TAKEDA**, Tokyo (JP); **Jing LEI**, San Diego, CA (US)

(57) **ABSTRACT**

Aspects described herein relate to recycling transmit or receive antennas from one band to another and accordingly modifying certain operations, which may include channel state information (CSI) reporting, sounding reference signal (SRS) transmission, and/or the like.

(21) Appl. No.: **18/608,708**

(22) Filed: **Mar. 18, 2024**

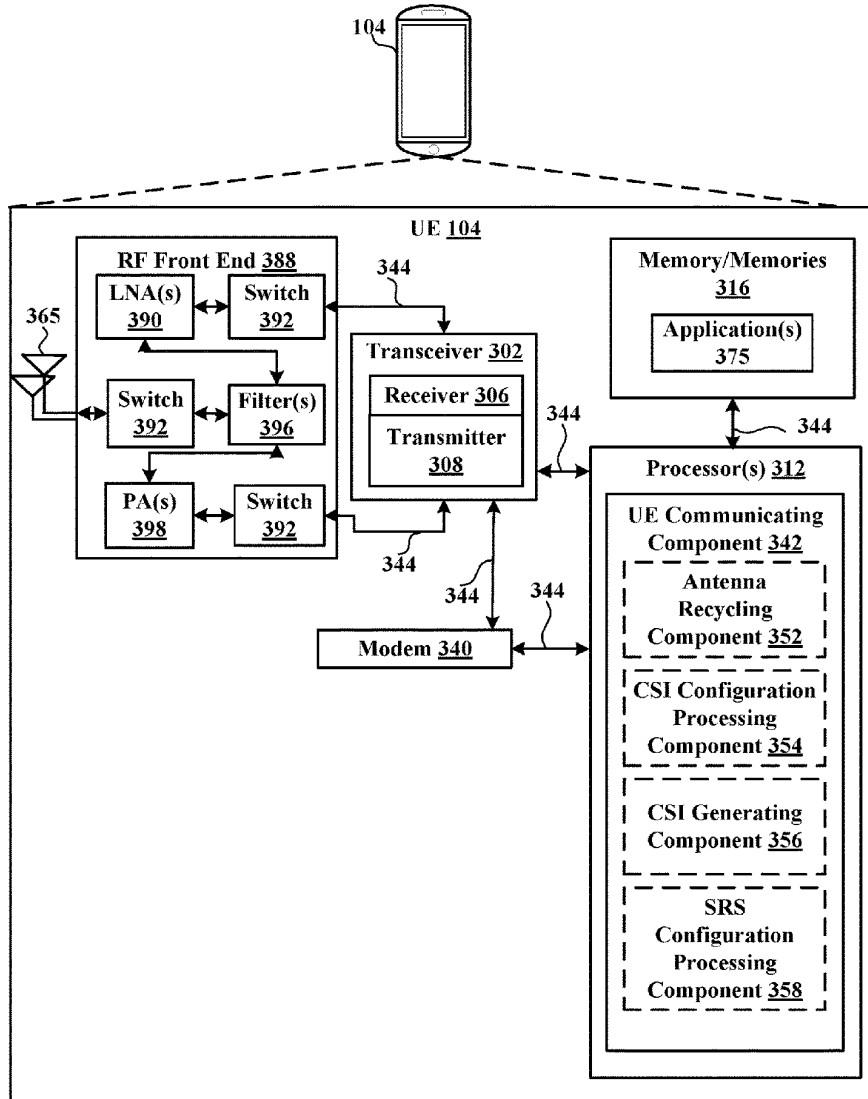



US 20250300341A1

(19) **United States**

(12) **Patent Application Publication**  
**GONG et al.**

(10) **Pub. No.: US 2025/0300341 A1**

(43) **Pub. Date: Sep. 25, 2025**

(54) **ANTENNA STRUCTURE AND ELECTRONIC DEVICE**

*H01Q 5/10* (2015.01)

*H01Q 5/20* (2015.01)

*H01Q 9/04* (2006.01)

(71) Applicant: **Wistron NeWeb Corporation**, Hsinchu (TW)

(52) **U.S. Cl.**

CPC ..... *H01Q 1/2266* (2013.01); *H01Q 1/48*

(2013.01); *H01Q 5/10* (2015.01); *H01Q 5/20*

(2015.01); *H01Q 9/0421* (2013.01)

(72) Inventors: **Yi-Ping GONG**, Hsinchu (TW);  
**Hong-Jun JIAN**, Hsinchu (TW)

(21) Appl. No.: **18/828,064**

(57)

**ABSTRACT**

(22) Filed: **Sep. 9, 2024**

(30) **Foreign Application Priority Data**

The antenna structure is disposed on a heat sink. The heat sink includes a top cover. The antenna structure includes a feeding portion, a grounding portion, and a radiation portion. A vertical projection of the radiation portion is completely overlapped with the top cover of the heat sink. The radiation portion includes a first branch and a second branch. One end of the second branch is vertically connected to the first branch, and another end of the second branch is connected to the feeding portion.

Mar. 19, 2024 (TW) ..... 113110044

**Publication Classification**

(51) **Int. Cl.**

*H01Q 1/22* (2006.01)

*H01Q 1/48* (2006.01)

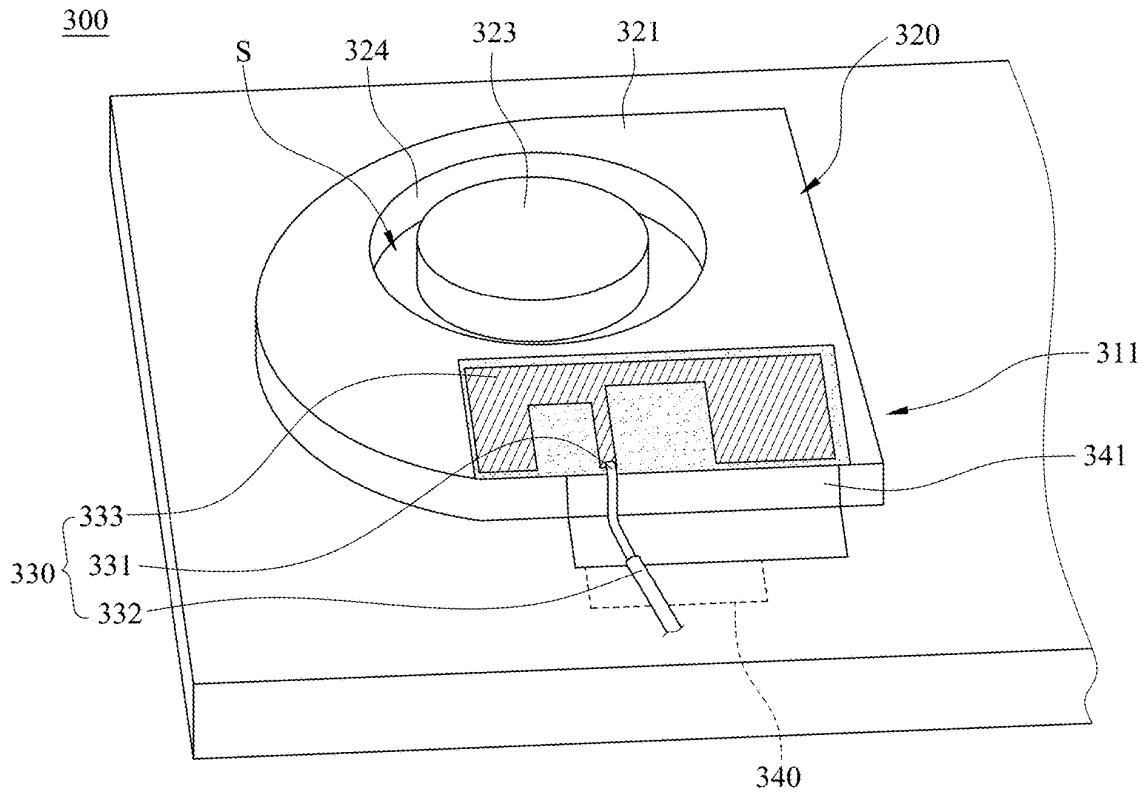



US 20250300345A1

(19) **United States**

(12) **Patent Application Publication**  
**Jo**

(10) **Pub. No.:** US 2025/0300345 A1

(43) **Pub. Date:** Sep. 25, 2025

(54) **ARTIFICIAL INTELLIGENCE EMPOWERED  
MULTI-LAYER COUPLING-CONTROLLED  
ANTENNA SYSTEM**

(52) **U.S. Cl.**  
CPC ..... **H01Q 1/521** (2013.01); **H01Q 9/20**  
(2013.01)

(71) Applicant: **SkyMirr, Inc.**, Melbourne, FL (US)

(57) **ABSTRACT**

(72) Inventor: **Youngmin Jo**, Melbourne, FL (US)

(21) Appl. No.: **18/908,282**

(22) Filed: **Oct. 7, 2024**

**Related U.S. Application Data**

(60) Provisional application No. 63/542,997, filed on Oct. 6, 2023.

**Publication Classification**

(51) **Int. Cl.**  
**H01Q 1/52** (2006.01)  
**H01Q 9/20** (2006.01)

An antenna system. The system comprises first and second spaced-apart antennas each one formed in an upper conductive layer and a lower conductive layer of a printed circuit board. Coupling structures (four coupling structures in one embodiment) disposed between the first and second antennas are formed in either the upper conductive layer or the lower conductive layer and conductively connected to one of the first antenna or the second antenna. The coupling structures formed in the upper conductive layer overlie those formed in the lower conductive layer. The direction of current flow in the coupling structures reduces interference between the electromagnetic fields radiated from the first and the second antennas.

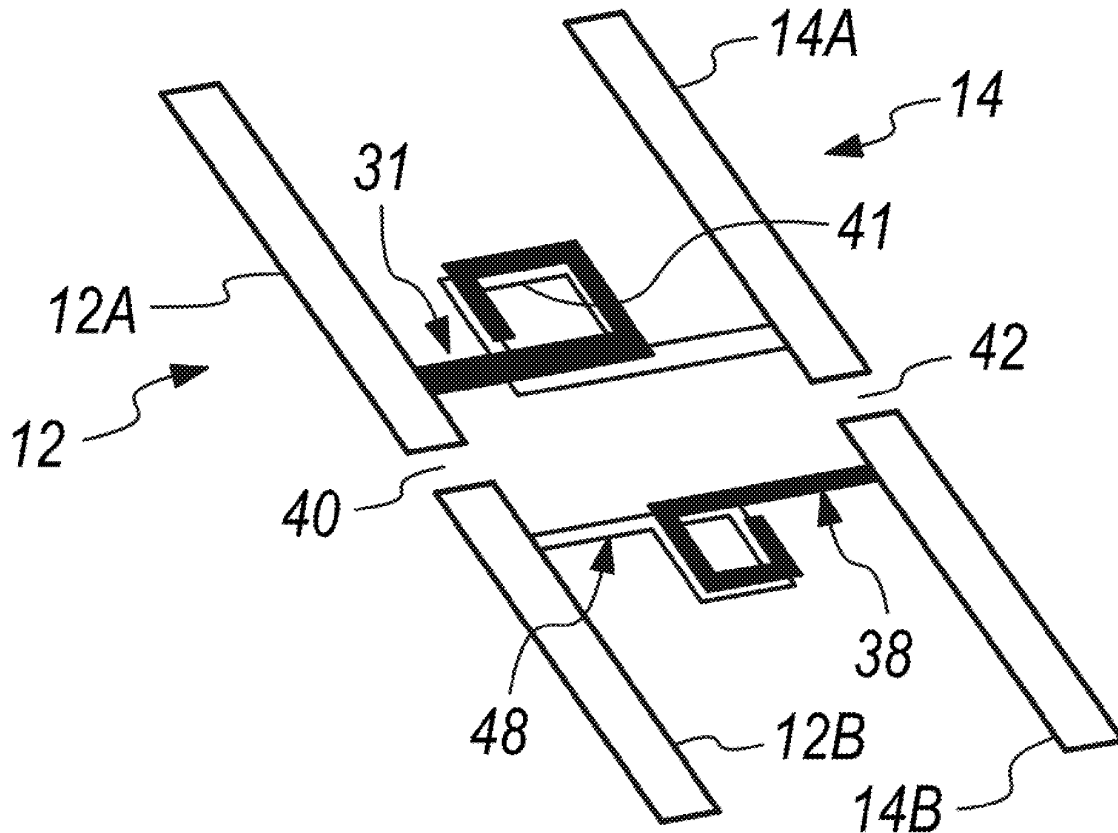



US 20250300350A1

(19) **United States**

(12) **Patent Application Publication**  
**CHANG**

(10) **Pub. No.: US 2025/0300350 A1**

(43) **Pub. Date: Sep. 25, 2025**

(54) **ANTENNA DEVICE**

(71) Applicant: **Getac Technology Corporation**, New Taipei City (TW)

(72) Inventor: **Yu-Yao CHANG**, Taipei City (TW)

(21) Appl. No.: **19/021,346**

(22) Filed: **Jan. 15, 2025**

(30) **Foreign Application Priority Data**

Mar. 22, 2024 (CN) ..... 202410333972.6

**Publication Classification**

(51) **Int. Cl.**  
*H01Q 7/00* (2006.01)  
*H01Q 5/20* (2015.01)  
*H01Q 5/314* (2015.01)  
*H01Q 9/04* (2006.01)

(52) **U.S. Cl.**

CPC ..... *H01Q 7/00* (2013.01); *H01Q 5/20* (2015.01); *H01Q 5/314* (2015.01); *H01Q 9/0407* (2013.01)

(57) **ABSTRACT**

An antenna device, comprising a loop antenna and a passive radiating element. The loop antenna comprises a first terminal of the loop antenna and a second terminal of the loop antenna. The first terminal of the loop antenna is coupled to a feed terminal, and the second terminal of the loop antenna is coupled to a ground terminal. The passive radiating element comprises a first terminal of the passive radiating element and a second terminal of the passive radiating element. The first terminal of the passive radiating element is coupled to the feed terminal, and the second terminal of the passive radiating element has a coupling section. The coupling section and at least one portion of the loop antenna are substantially parallel to each other and have a first spacing to form a coupling capacitor.

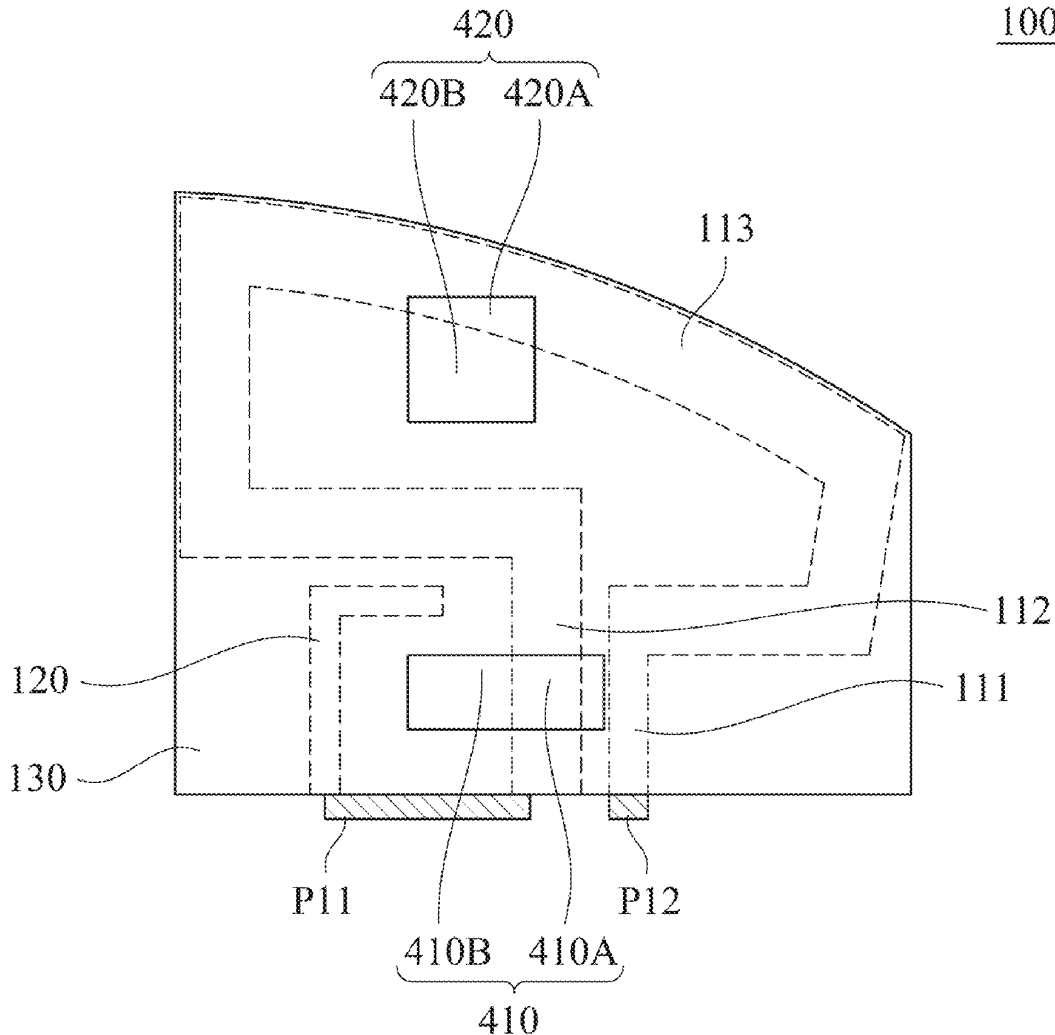





US 20250300362A1

(19) **United States**

(12) **Patent Application Publication**  
**XIANG**

(10) **Pub. No.: US 2025/0300362 A1**

(43) **Pub. Date: Sep. 25, 2025**

(54) **ANTENNA UNIT, ANTENNA ARRAY, AND ELECTRONIC DEVICE**

(52) **U.S. Cl.**  
CPC ..... **H01Q 19/005** (2013.01); **H01Q 9/0407** (2013.01); **H01Q 21/065** (2013.01)

(71) Applicant: **Beijing Xiaomi Mobile Software Co., Ltd.**, Beijing (CN)

(72) Inventor: **Lei XIANG**, Beijing (CN)

(57) **ABSTRACT**

(21) Appl. No.: **18/888,723**

(22) Filed: **Sep. 18, 2024**

(30) **Foreign Application Priority Data**

Mar. 22, 2024 (CN) ..... 202410339353.8

**Publication Classification**

(51) **Int. Cl.**  
**H01Q 19/00** (2006.01)  
**H01Q 9/04** (2006.01)  
**H01Q 21/06** (2006.01)

An antenna unit includes: a radiation assembly including at least one parasitic patch and at least one radiation patch; a dielectric layer including a layer of dielectric substrate; a floor layer; and at least one feed structure, wherein the radiation assembly is located on a top surface of the dielectric layer; the floor layer is located on a bottom surface of the dielectric layer; and the least one feed structure passes through the floor layer and the dielectric layer sequentially and is electrically connected to the at least one parasitic patch, and the at least one parasitic patch is coupled to the at least one radiation patch.

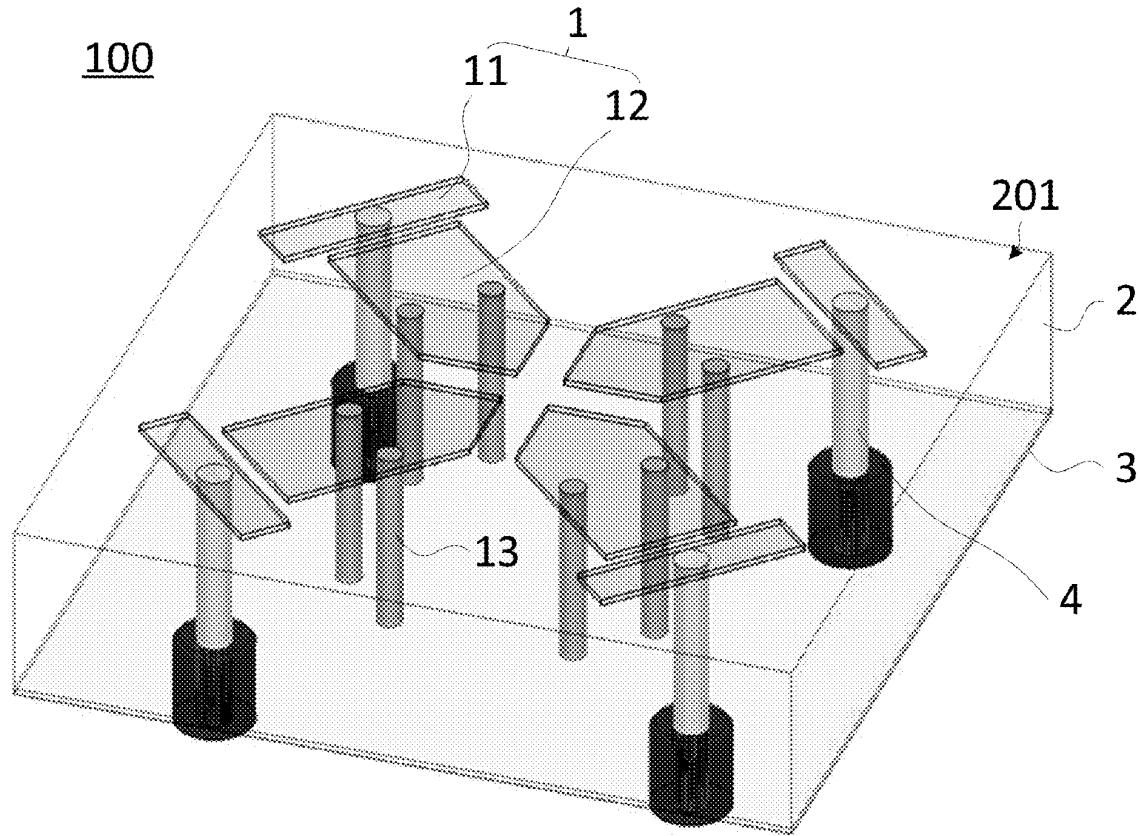



US 20250300368A1

(19) **United States**

(12) **Patent Application Publication**  
**SATO**

(10) **Pub. No.: US 2025/0300368 A1**

(43) **Pub. Date: Sep. 25, 2025**

(54) **ANTENNA MODULE AND COMMUNICATION APPARATUS EQUIPPED WITH THE SAME**

**Publication Classification**

(51) **Int. Cl.**  
*H01Q 21/24* (2006.01)  
*H01Q 1/52* (2006.01)  
*H01Q 5/28* (2015.01)

(71) Applicant: **Murata Manufacturing Co., Ltd.**,  
Nagaokakyo-shi (JP)

(52) **U.S. Cl.**  
CPC ..... *H01Q 21/24* (2013.01); *H01Q 1/52* (2013.01); *H01Q 5/28* (2015.01)

(72) Inventor: **Yosuke SATO**, Nagaokakyo-shi (JP)

(73) Assignee: **Murata Manufacturing Co., Ltd.**,  
Nagaokakyo-shi (JP)

(57) **ABSTRACT**

(21) Appl. No.: **19/232,035**

An antenna module includes a ground electrode, a first radiating element, a second radiating element larger in size than the first radiating element, a feed wiring line, and a metal member. The first and second radiating elements face the ground electrode. The first and second radiating elements overlap each other in plan view in the normal direction of the ground electrode. The feed wiring line penetrates through the radiating element and a radio frequency signal is transmitted therethrough to the radiating element. The metal member extends from the radiating element in the normal direction without contacting the ground electrode.

(22) Filed: **Jun. 9, 2025**

**Related U.S. Application Data**

(63) Continuation of application No. PCT/JP2023/036696, filed on Oct. 10, 2023.

**Foreign Application Priority Data**

Dec. 22, 2022 (JP) ..... 2022-205878

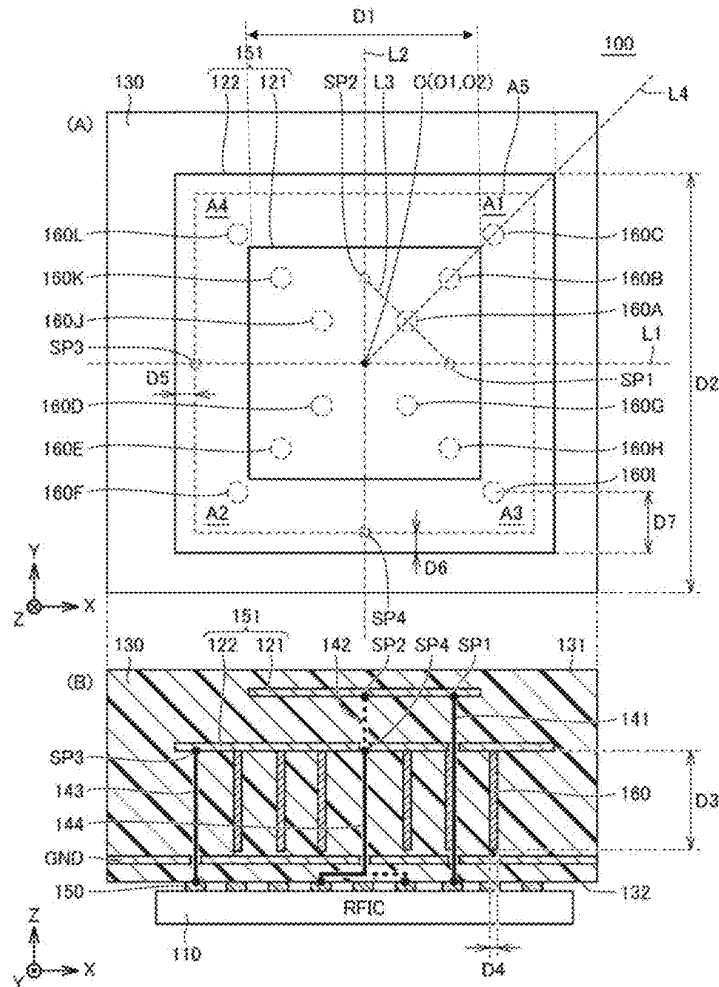



US 20250309521A1

(19) **United States**

(12) **Patent Application Publication**  
**Cox**

(10) **Pub. No.: US 2025/0309521 A1**

(43) **Pub. Date: Oct. 2, 2025**

(54) **HYBRID ANTENNA FOR BIOMETRIC INSERT, CORE LAYER AND INFORMATION CARRYING CARD COMPRISING THE SAME**

(71) Applicant: **SentryCard Technologies, Inc.**,  
Chicago, IL (US)

(72) Inventor: **Mark Cox**, West Chester, PA (US)

(21) Appl. No.: **19/091,345**

(22) Filed: **Mar. 26, 2025**

**Related U.S. Application Data**

(60) Provisional application No. 63/570,967, filed on Mar. 28, 2024.

**Publication Classification**

(51) **Int. Cl.**  
**H01Q 1/22** (2006.01)  
**B32B 3/08** (2006.01)  
**B32B 7/12** (2006.01)  
**B32B 27/30** (2006.01)  
**H01Q 7/00** (2006.01)

(52) **U.S. Cl.**  
CPC ..... **H01Q 1/2208** (2013.01); **B32B 3/08**  
(2013.01); **B32B 3/085** (2013.01); **B32B 7/12**  
(2013.01); **B32B 27/304** (2013.01); **H01Q**  
**7/00** (2013.01); **B32B 2250/24** (2013.01);  
**B32B 2255/10** (2013.01); **B32B 2255/26**  
(2013.01); **B32B 2307/412** (2013.01); **B32B**  
**2307/75** (2013.01); **B32B 2425/00** (2013.01);  
**B32B 2457/00** (2013.01); **B32B 2519/02**  
(2013.01)

(57) **ABSTRACT**

The present disclosure provides a core sheet, a core layer comprising the core sheet for an information carrying card, an information carrying card comprising the same, and the methods of making the core sheet, the core layer, and the information carrying card. The core sheet includes a substrate film such as a thermoplastic film, and an antenna structure disposed on or embedded within the substrate film. The antenna structure includes a wire made of a conductive material and comprises a first antenna portion including a first number of loops and configured to communicate with a first RF frequency. The antenna structure further includes a second antenna portion including at least one portion having a waveform structure.

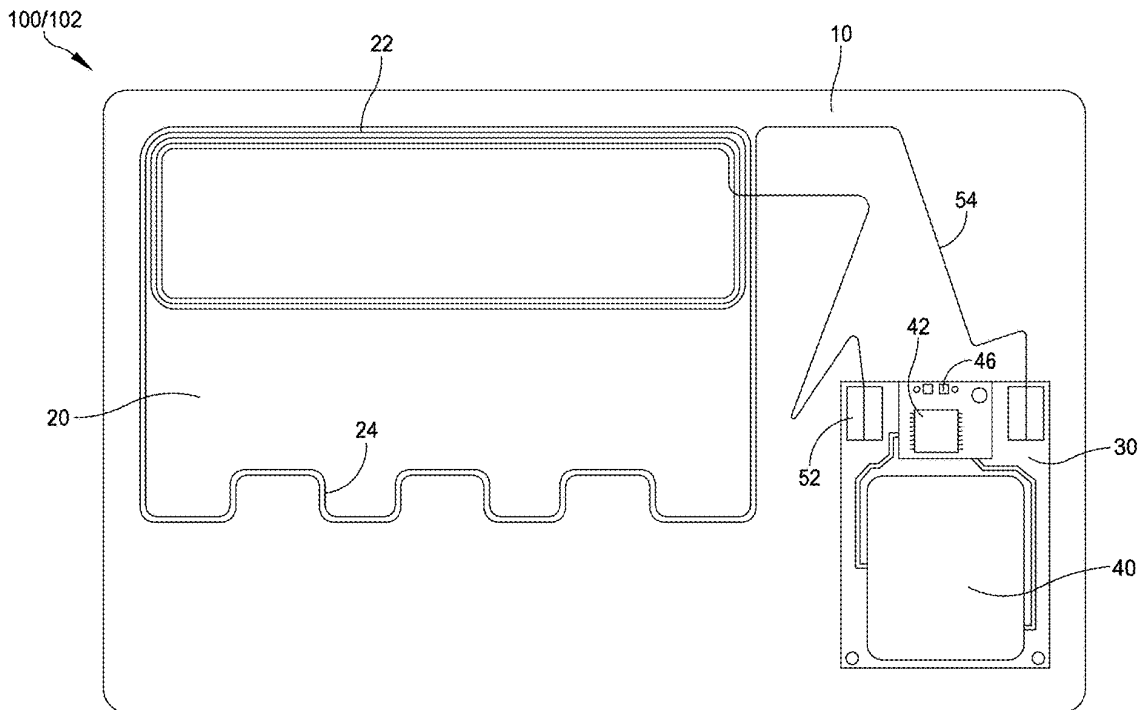



US 20250309524A1

(19) **United States**

(12) **Patent Application Publication**  
**SVENSSON et al.**

(10) **Pub. No.: US 2025/0309524 A1**  
(43) **Pub. Date: Oct. 2, 2025**

(54) **AN ANTENNA ARRANGEMENT**  
(71) Applicant: **SAAB AB**, Linköping (SE)  
(72) Inventors: **Bengt SVENSSON**, Mölndal (SE);  
**Anders HÖÖK**, Hindås (SE); **Glenn SJÖBERG**, Göteborg (SE); **Daniel SJÖBERG**, Malmö (SE); **Alexandros PALLARIS**, Lund (SE)

**H01Q 1/50** (2006.01)  
**H01Q 5/15** (2015.01)  
**H01Q 5/30** (2015.01)  
**H01Q 9/16** (2006.01)  
(52) **U.S. Cl.**  
CPC ..... **H01Q 1/32** (2013.01); **H01Q 1/42** (2013.01); **H01Q 1/50** (2013.01); **H01Q 5/15** (2015.01); **H01Q 5/30** (2015.01); **H01Q 9/16** (2013.01)

(21) Appl. No.: **18/866,582**  
(22) PCT Filed: **May 16, 2023**  
(86) PCT No.: **PCT/SE2023/050482**  
§ 371 (c)(1),  
(2) Date: **Nov. 18, 2024**

(30) **Foreign Application Priority Data**  
May 18, 2022 (SE) ..... 2200055-8

**Publication Classification**  
(51) **Int. Cl.**  
**H01Q 1/32** (2006.01)  
**H01Q 1/42** (2006.01)

(57) **ABSTRACT**  
The present disclosure relates to an antenna arrangement including a first antenna configured to operate within a first frequency band and a planar layer having an oblong conducting structure attached thereon, the conducting structure being arranged within an illumination-field of the first antenna. Further including a plurality of capacitive strips arranged on opposing longitudinal portions of the planar layer extending along a length of the conducting structure, the longitudinal portions being separated by the conducting structure.

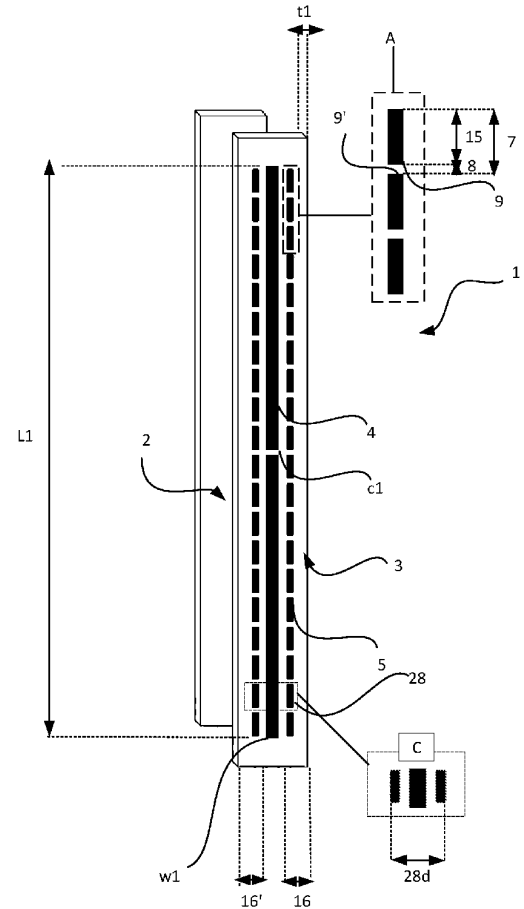



US 20250309528A1

(19) **United States**

(12) **Patent Application Publication**  
LV et al.

(10) **Pub. No.: US 2025/0309528 A1**

(43) **Pub. Date: Oct. 2, 2025**

(54) **ANTENNA, ANTENNA ASSEMBLY, AND  
BASE STATION**

**Publication Classification**

(71) Applicant: **HUAWEI TECHNOLOGIES CO.,  
LTD.**, Shenzhen (CN)

(51) **Int. Cl.**  
*H01Q 1/42* (2006.01)  
*H01Q 1/24* (2006.01)  
*H01Q 19/10* (2006.01)  
*H01Q 21/06* (2006.01)

(72) Inventors: **Jinsong LV**, Shanghai (CN); **Tao PU**,  
Shanghai (CN); **Weihong XIAO**,  
Dongguan (CN); **Jia LV**, Shanghai  
(CN); **Zhiqiang LIAO**, Shenzhen (CN)

(52) **U.S. Cl.**  
CPC ..... *H01Q 1/42* (2013.01); *H01Q 1/246*  
(2013.01); *H01Q 19/10* (2013.01); *H01Q*  
*21/06* (2013.01)

(21) Appl. No.: **19/237,318**

(57) **ABSTRACT**

(22) Filed: **Jun. 13, 2025**

An antenna, an antenna assembly, and a base station includes a radome, a first antenna portion, and a second antenna portion. The first antenna portion is disposed inside the radome, and the second antenna portion is coupled to the first antenna portion, disposed outside the radome, and exposed to a surrounding environment. In this way, the radome does not need to cover the entire antenna, but covers only a portion of the antenna. Therefore, a wind load acting on a support structure by using the radome can be reduced. In addition, a cavity is provided to accommodate transmission lines of the antenna together, so that use of a connecting device such as a jumper can be reduced or even avoided, to reduce a transmission loss of the antenna.

**Related U.S. Application Data**

(63) Continuation of application No. PCT/CN2023/  
136912, filed on Dec. 6, 2023.

**Foreign Application Priority Data**

(30) Dec. 14, 2022 (CN) ..... 202211610512.0

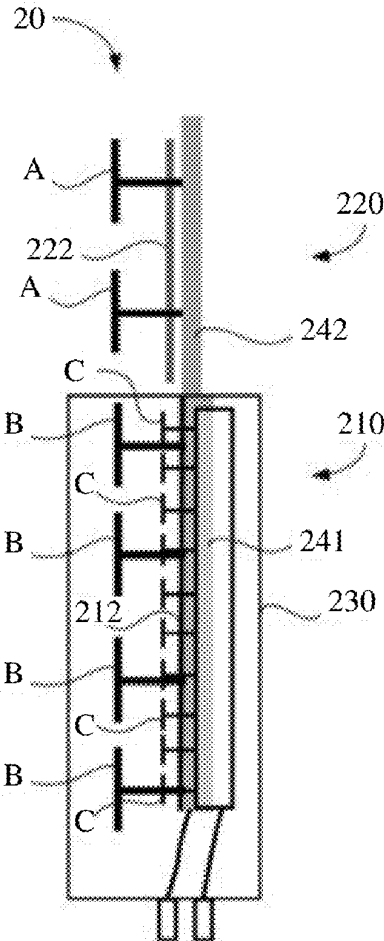



US 20250309534A1

(19) **United States**

(12) **Patent Application Publication**  
**LIN et al.**

(10) **Pub. No.: US 2025/0309534 A1**

(43) **Pub. Date: Oct. 2, 2025**

(54) **ANTENNA CIRCUIT BOARD AND ANTENNA MODULE WITH PLURAL FREQUENCY BANDS**

*H01Q 5/10* (2015.01)

*H01Q 5/50* (2015.01)

(71) Applicants: **FOXCONN (KUNSHAN) COMPUTER CONNECTOR CO., LTD.**, Kunshan (CN); **FOXCONN INTERCONNECT TECHNOLOGY LIMITED**, Grand Cayman (KY)

(52) **U.S. Cl.**  
CPC ..... *H01Q 5/25* (2015.01); *H01Q 1/48* (2013.01); *H01Q 5/10* (2015.01); *H01Q 5/50* (2015.01)

(72) Inventors: **KUN-RONG LIN**, New Taipei (TW); **Yu-Jen Chen**, New Taipei (TW); **Lung-Sheng Tai**, New Taipei (TW); **Chun-Ta Lee**, New Taipei (TW)

(57) **ABSTRACT**

An antenna module includes: a frame; a circuit board on an upper side of the frame, which defines an upper and a lower face, a first side edge and having a first and a second radiator area at the upper face; a lower bracket on a lower side of the frame, wherein the first radiator area comprises a first current path and plural signal feeding points, the second radiator area comprises a second current path close to the first side edge, and plural first grounding feeding points, the second and the third current path extend in two different directions, the second current path is spaced away from the first side edge by a first gap, the first, second and third current path transmit signals in three different frequency bands, and the first radiator area is connected to the second radiator area by a fourth current path.

(21) Appl. No.: **19/093,883**

(22) Filed: **Mar. 28, 2025**

(30) **Foreign Application Priority Data**

Mar. 30, 2024 (CN) ..... 202420646379.2

**Publication Classification**

(51) **Int. Cl.**  
*H01Q 5/25* (2015.01)  
*H01Q 1/48* (2006.01)

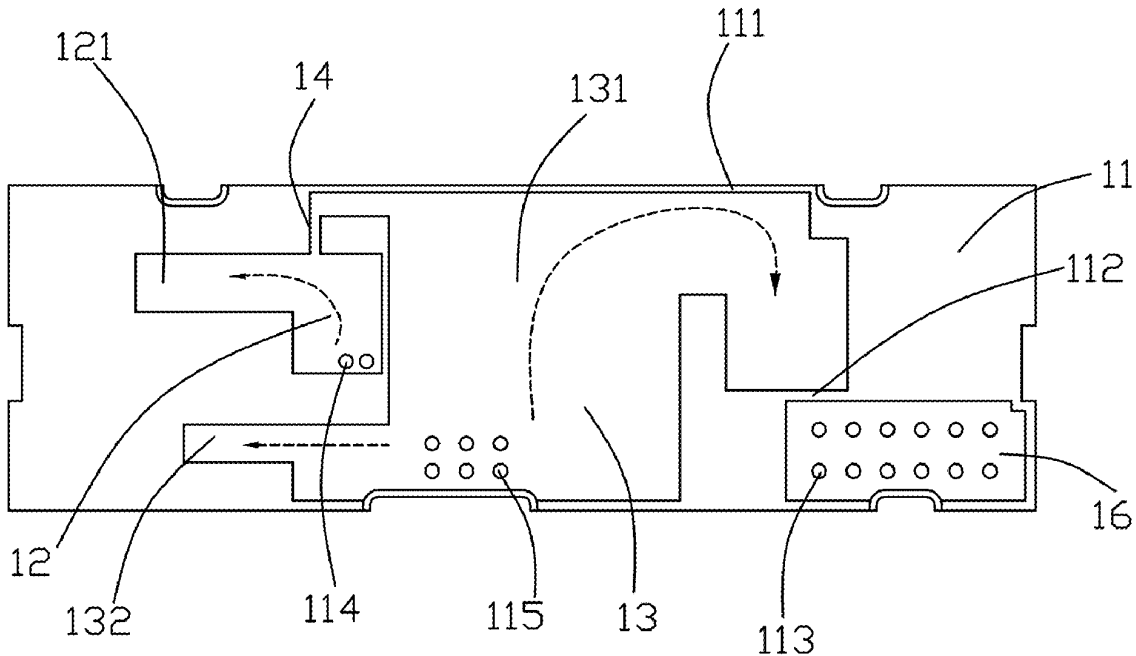



US 20250309539A1

(19) **United States**

(12) **Patent Application Publication**  
**LIN et al.**

(10) **Pub. No.: US 2025/0309539 A1**

(43) **Pub. Date: Oct. 2, 2025**

(54) **ANTENNA SUBSTRATE, ELECTRONIC PACKAGE AND MANUFACTURING METHOD THEREOF**

*H01Q 1/42* (2006.01)

*H01Q 21/06* (2006.01)

(71) Applicant: **SILICONWARE PRECISION INDUSTRIES CO., LTD.**, Taichung City (TW)

(52) **U.S. Cl.**  
CPC ..... *H01Q 9/0407* (2013.01); *H01Q 1/422* (2013.01); *H01Q 21/065* (2013.01); *H01Q 1/38* (2013.01)

(72) Inventors: **I-Hsien LIN**, Taichung City (TW);  
**Yu-Min LO**, Taichung City (TW);  
**Chih-Chun YANG**, Taichung City (TW);  
**Mu-Hsuan CHAN**, Taichung City (TW)

(57) **ABSTRACT**

An antenna substrate, electronic package and manufacturing method thereof are provided in which an antenna substrate including a silicon core layer, a circuit structure and conductive pillars, and the circuit structure has a first dielectric layer, a first circuit layer and a first antenna portion. The circuit structure and the conductive pillars are formed on opposite sides of the silicon core layer, and the antenna substrate is stacked and bonded to a circuit board having a second antenna portion through the conductive pillars. Thereby, the present disclosure can thin a thickness of the antenna substrate and the electronic package, or precisely control a distance between the antenna substrate and the circuit board.

(21) Appl. No.: **18/882,213**

(22) Filed: **Sep. 11, 2024**

(30) **Foreign Application Priority Data**

Apr. 2, 2024 (TW) ..... 113112562

**Publication Classification**

(51) **Int. Cl.**  
*H01Q 9/04* (2006.01)  
*H01Q 1/38* (2006.01)

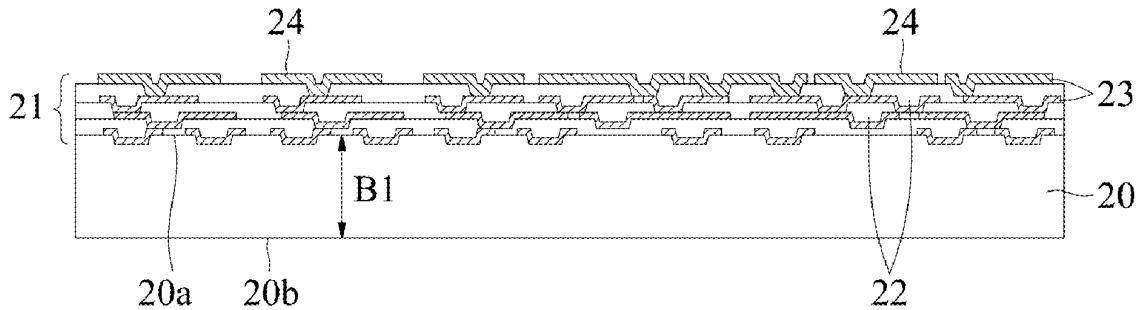





US 20250309546A1

(19) **United States**

(12) **Patent Application Publication**  
**Chiu et al.**

(10) **Pub. No.: US 2025/0309546 A1**

(43) **Pub. Date: Oct. 2, 2025**

(54) **DOUBLE SLOT ANTENNA**

**Publication Classification**

(71) Applicant: **KYOCERA AVX Components (San Diego), Inc.**, San Diego, CA (US)

(51) **Int. Cl.**  
**H01Q 13/10** (2006.01)  
**H01Q 1/22** (2006.01)  
**H01Q 5/30** (2015.01)

(72) Inventors: **Tzu Ling Chiu**, New Taipei City (TW);  
**Jui Feng Wu**, New Taipei City (TW)

(52) **U.S. Cl.**  
CPC ..... **H01Q 13/10** (2013.01); **H01Q 1/2266**  
(2013.01); **H01Q 5/30** (2015.01)

(21) Appl. No.: **19/092,725**

(57) **ABSTRACT**

(22) Filed: **Mar. 27, 2025**

A double slot antenna is provided. The double slot antenna includes an antenna element defining a reference plane, the antenna element being partially enclosed by a metal frame along the reference plane. The double slot antenna further includes an inner slot defined within the antenna element along the reference plane. The double slot antenna further includes an outer slot defined between the antenna element and a metal frame along the reference plane. The metal frame comprises a notch.

**Related U.S. Application Data**

(60) Provisional application No. 63/571,859, filed on Mar. 29, 2024.

600

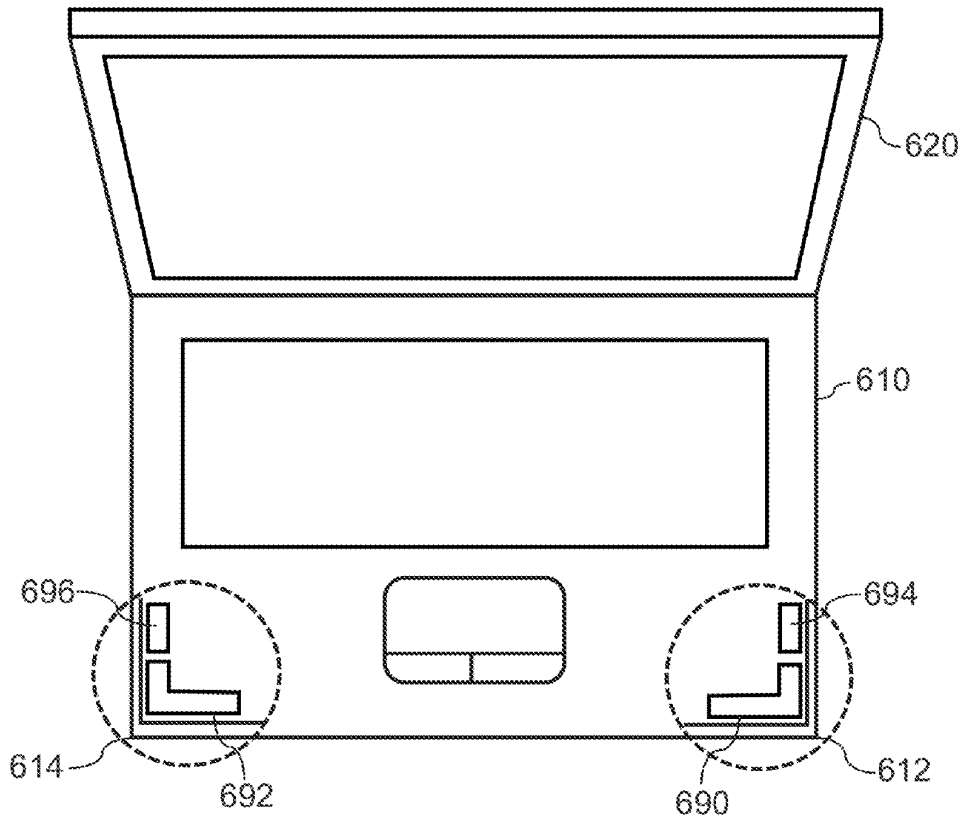



US 20250309558A1

(19) **United States**

(12) **Patent Application Publication**  
**AKIMOTO et al.**

(10) **Pub. No.:** US 2025/0309558 A1

(43) **Pub. Date:** Oct. 2, 2025

(54) **ANTENNA DEVICE**

**Publication Classification**

(71) Applicant: **Mitsubishi Electric Corporation,**  
Tokyo (JP)

(51) **Int. Cl.**  
*H01Q 19/00* (2006.01)  
*H01Q 1/12* (2006.01)  
*H01Q 9/26* (2006.01)  
*H01Q 9/30* (2006.01)

(72) Inventors: **Shimpei AKIMOTO,** Tokyo (JP);  
**Kengo NISHIMOTO,** Tokyo (JP)

(52) **U.S. Cl.**  
CPC ..... *H01Q 19/005* (2013.01); *H01Q 1/1271*  
(2013.01); *H01Q 9/26* (2013.01); *H01Q 9/30*  
(2013.01)

(73) Assignee: **Mitsubishi Electric Corporation,**  
Tokyo (JP)

(21) Appl. No.: **19/240,193**

(57) **ABSTRACT**

(22) Filed: **Jun. 17, 2025**

An antenna device includes: a transparent antenna conductor including a notch; a glass provided with the antenna conductor; a metal sash provided adjacent to the antenna conductor; and an opaque antenna conductor provided to the metal sash without contacting the antenna conductor, and disposed adjacent to the notch without protruding from the metal sash toward the glass.

**Related U.S. Application Data**

(63) Continuation of application No. PCT/JP2023/007931, filed on Mar. 3, 2023.

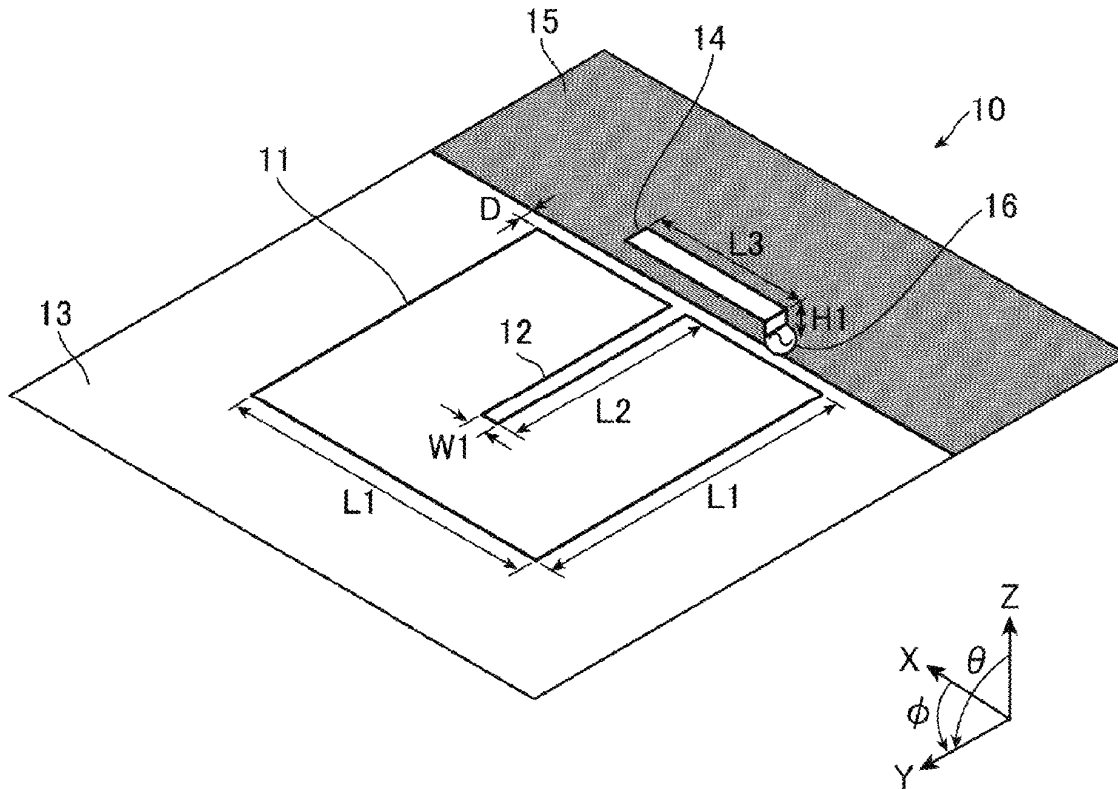



US 20250309563A1

(19) **United States**

(12) **Patent Application Publication**  
**SKINNER et al.**

(10) **Pub. No.: US 2025/0309563 A1**

(43) **Pub. Date: Oct. 2, 2025**

(54) **MULTI-FEED ANTENNA STRUCTURES**

(22) Filed: **Feb. 25, 2025**

(71) Applicant: **Intel Corporation**, Santa Clara, CA (US)

(30) **Foreign Application Priority Data**

Mar. 27, 2024 (EP) ..... 24 166 791.4

(72) Inventors: **Harry SKINNER**, Beaverton, OR (US); **Ofir DEGANI**, Nes-Ammin (IL); **Ronen KRONFELD**, Shoham (IL); **Jayprakash THAKUR**, Bangalore (IN); **John ROMAN**, Hillsboro, OR (US); **Nawfal ASRIH**, Mandelieu-la-Napoule (FR); **Seong-Youp SUH**, Portland, OR (US); **Tae Young YANG**, Portland, OR (US); **Serge DAO**, Vallauris (FR); **Walid EL HAJJ**, Antibes (FR); **Oren Ezra AVRAHAM**, Givat Shmuel (IL); **Jay Vishnu GUPTA**, Bengaluru (IN); **Prathibha PEDDIREDDY**, Bangalore (IN)

**Publication Classification**

(51) **Int. Cl.**  
*H01Q 21/28* (2006.01)  
*H01Q 5/378* (2015.01)  
*H01Q 15/00* (2006.01)  
(52) **U.S. Cl.**  
CPC ..... *H01Q 21/28* (2013.01); *H01Q 5/378* (2015.01); *H01Q 15/0086* (2013.01)

(57) **ABSTRACT**

A multi-feed antenna structure may include a first antenna port; a first radiating structure coupled to the first antenna port; a second antenna port; a second radiating structure coupled to the second antenna port; and an electromagnetic structure located between the first radiating structure and the second radiating structure.

(21) Appl. No.: **19/062,151**

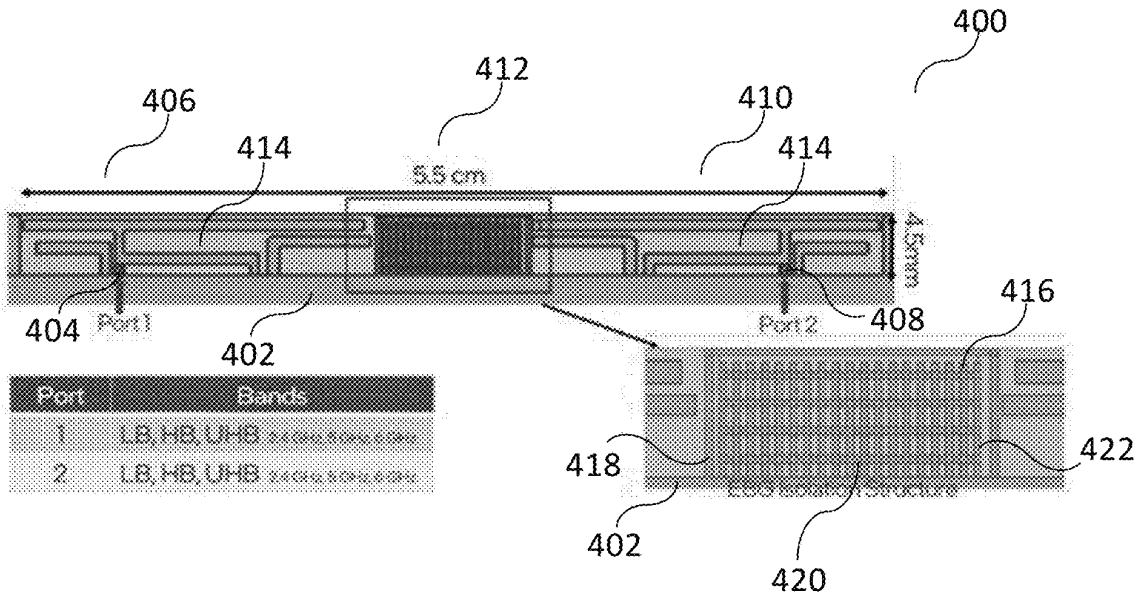



US 20250309566A1

(19) **United States**

(12) **Patent Application Publication**  
**ABE et al.**

(10) **Pub. No.: US 2025/0309566 A1**

(43) **Pub. Date: Oct. 2, 2025**

(54) **ANTENNA MODULE**

**Publication Classification**

(71) Applicant: **TDK Corporation**, Tokyo (JP)

(51) **Int. Cl.**  
**H01Q 23/00** (2006.01)  
**H01Q 1/24** (2006.01)  
**H05K 3/46** (2006.01)

(72) Inventors: **Toshiyuki ABE**, Tokyo (JP); **Kazutoshi TSUYUTANI**, Tokyo (JP); **Kazuhiro YOSHIKAWA**, Tokyo (JP); **Hiroyuki NISHIOKA**, Tokyo (JP); **Naoyuki ISHIKAWA**, Tokyo (JP)

(52) **U.S. Cl.**  
CPC ..... **H01Q 23/00** (2013.01); **H01Q 1/24** (2013.01); **H05K 3/46** (2013.01)

(57) **ABSTRACT**

To provide an antenna module incorporating an electronic component such as an RFIC. An antenna module includes a core substrate, an outermost insulating layer, and a resin layer provided between the core substrate and the outermost insulating layer and embedding therein an RFIC. The core substrate has a core layer, insulating layers and sandwiching the core layer, a through hole conductor connecting conductor layers to, an antenna layer, and feeding patterns and, a via conductor connecting the feeding pattern and a feeding pattern, and a via conductor connecting an antenna pattern and the feeding pattern. The resin layer has a conductor layer connected to the RFIC. The conductor layer is larger in thickness than the conductor layer, which makes cracks or disconnection unlikely to occur in the conductor layer while achieving fine pitch of the conductor layer.

(21) Appl. No.: **18/855,768**

(22) PCT Filed: **Feb. 6, 2023**

(86) PCT No.: **PCT/JP2023/003698**

§ 371 (c)(1),  
(2) Date: **Oct. 10, 2024**

(30) **Foreign Application Priority Data**

Apr. 15, 2022 (JP) ..... 2022-067461

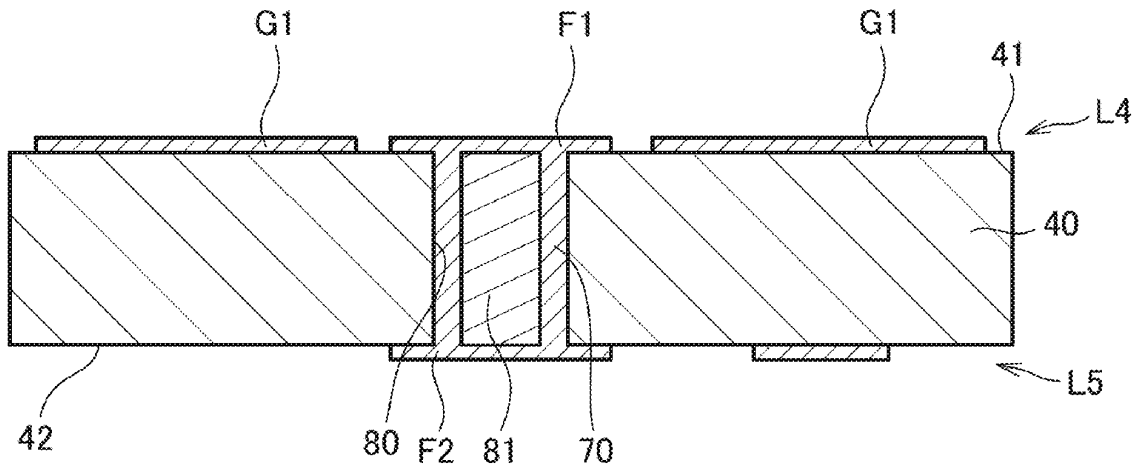



US 20250316881A1

(19) **United States**

(12) **Patent Application Publication**  
**YANG**

(10) **Pub. No.: US 2025/0316881 A1**

(43) **Pub. Date: Oct. 9, 2025**

(54) **FOLDABLE RECEIVING ANTENNA AND FOLDABLE PANEL PROVIDED THEREWITH**

(52) **U.S. Cl.**  
CPC ..... **H01Q 1/08** (2013.01); **H01Q 1/24** (2013.01); **H01Q 9/285** (2013.01)

(71) Applicant: **Shenzhen Antop Technology Co., Ltd.**,  
Shenzhen (CN)

(57) **ABSTRACT**

(72) Inventor: **Ruidian YANG**, Shenzhen (CN)

(21) Appl. No.: **18/913,756**

(22) Filed: **Oct. 11, 2024**

(30) **Foreign Application Priority Data**

Apr. 9, 2024 (CN) ..... 202420724770.X

**Publication Classification**

(51) **Int. Cl.**  
**H01Q 1/08** (2006.01)  
**H01Q 1/24** (2006.01)  
**H01Q 9/28** (2006.01)

A foldable receiving antenna has an antenna body which is divided into a plurality of folding units by at least one folding crease, wherein the antenna body has a plurality of layers, including a connecting layer spanning the folding crease for connecting adjacent two folding units, a centrally located support layer, a cover layer centrally symmetrically arranged at the both sides of the support layer, and an antenna layer disposed between the support layer and the cover layer. The foldable receiving antenna is free from large size and expensive pack and transport cost, inconvenient receiving direction of the antenna, and aesthetically unpleasing caused by thick thickness of the antenna mounted on an ultra-thin TV.

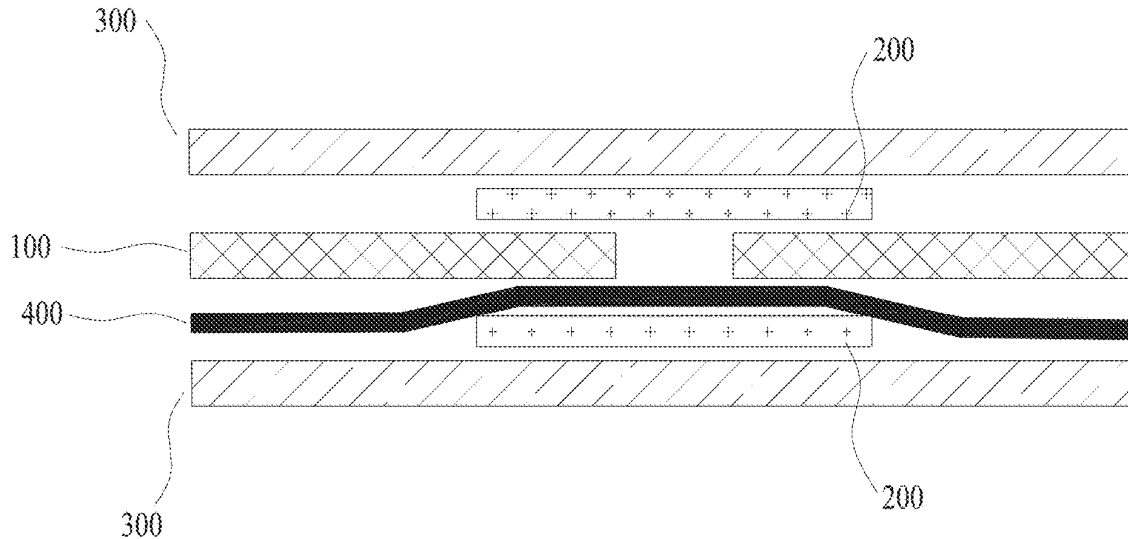



US 20250316884A1

(19) **United States**

(12) **Patent Application Publication**  
**LIAO et al.**

(10) **Pub. No.: US 2025/0316884 A1**

(43) **Pub. Date: Oct. 9, 2025**

(54) **ELECTRONIC DEVICE AND NEAR FIELD COMMUNICATION ANTENNA THEREOF**

**Publication Classification**

(71) Applicant: **PEGATRON CORPORATION**,  
TAIPEI CITY (TW)

(72) Inventors: **Chih-Wei LIAO**, TAIPEI CITY (TW);  
**Huan-Chia CHANG**, TAIPEI CITY (TW);  
**Chien-Yi WU**, TAIPEI CITY (TW);  
**Chao-Hsu WU**, TAIPEI CITY (TW);  
**Chen-Kuang WANG**, TAIPEI CITY (TW);  
**Cheng-Hsiung WU**, TAIPEI CITY (TW);  
**Shih-Keng HUANG**, TAIPEI CITY (TW);  
**Chia-Hung CHEN**, TAIPEI CITY (TW);  
**Hau-Yuen TAN**, TAIPEI CITY (TW)

(51) **Int. Cl.**  
**H01Q 1/22** (2006.01)  
**H01Q 7/00** (2006.01)

(52) **U.S. Cl.**  
CPC ..... **H01Q 1/22** (2013.01); **H01Q 7/00** (2013.01)

(21) Appl. No.: **19/082,331**

(22) Filed: **Mar. 18, 2025**

(30) **Foreign Application Priority Data**

Apr. 3, 2024 (TW) ..... 113112837

(57) **ABSTRACT**

An electronic device includes a metal back cover, a wiring board, a near field communication antenna, and a display front cover. The metal back cover includes a shell, a groove, and an accommodating groove. The groove and the accommodating groove are formed at the shell, respectively. The near field communication antenna is fixed in the groove. The near field communication antenna linearly extends in a long axis direction of the groove and is electrically connected with the wiring board. The display front cover covers the shell, the accommodating groove, the groove, and the near field communication antenna, and is electrically connected with the wiring board.

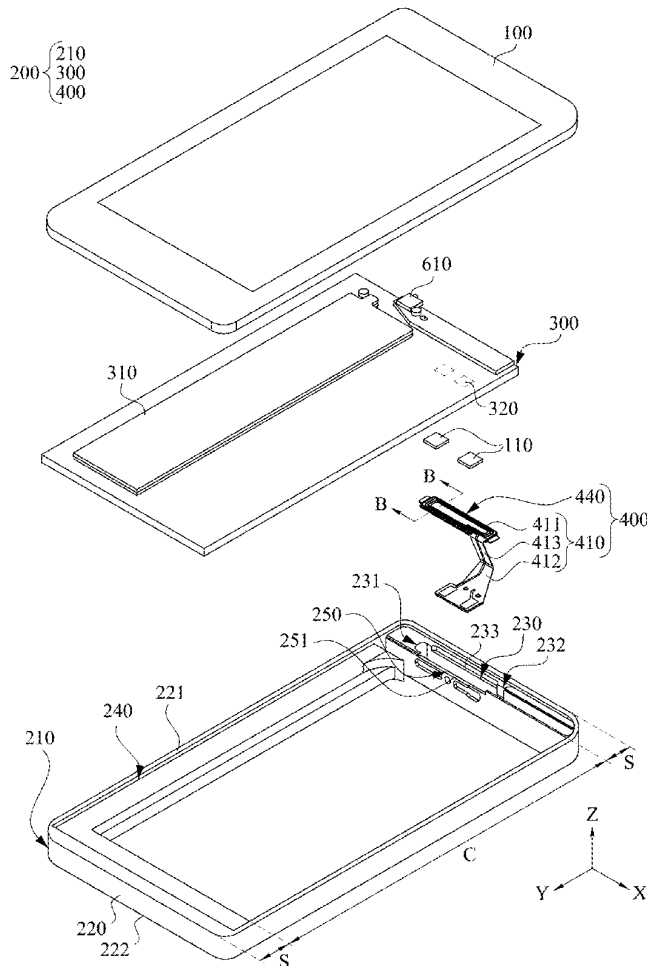



US 20250316899A1

(19) **United States**

(12) **Patent Application Publication**  
**HONG et al.**

(10) **Pub. No.: US 2025/0316899 A1**

(43) **Pub. Date: Oct. 9, 2025**

(54) **ANTENNA STRUCTURE**

**Publication Classification**

(71) Applicant: **POSTECH RESEARCH AND BUSINESS DEVELOPMENT FOUNDATION**, Pohang-Si (KR)

(51) **Int. Cl.**  
*H01Q 5/30* (2015.01)  
*H01Q 1/48* (2006.01)  
*H01Q 9/04* (2006.01)

(72) Inventors: **Won Bin HONG**, Seoul (KR); **Bum Hyun KIM**, Pohang-si (KR)

(52) **U.S. Cl.**  
CPC ..... *H01Q 5/30* (2015.01); *H01Q 1/48* (2013.01); *H01Q 9/045* (2013.01)

(73) Assignee: **POSTECH RESEARCH AND BUSINESS DEVELOPMENT FOUNDATION**, Pohang-Si (KR)

(57) **ABSTRACT**

(21) Appl. No.: **18/715,088**

An antenna structure is disclosed. The antenna structure according to one aspect includes: a radiator; a first transmission line and a second transmission line which extend in different directions from each other to be connected to the radiator; a first side ground pad disposed adjacent to the first transmission line; a second side ground pad disposed adjacent to the second transmission line; and a central ground pad disposed between the first transmission line and the second transmission line, wherein the central ground pad includes a slit part, and a length of the central ground pad is longer than the lengths of the first side ground pad and the second side ground pad.

(22) PCT Filed: **Apr. 4, 2022**

(86) PCT No.: **PCT/KR2022/004784**

§ 371 (c)(1),

(2) Date: **Oct. 24, 2024**

(30) **Foreign Application Priority Data**

Dec. 2, 2021 (KR) ..... 10-2021-0171275

100c

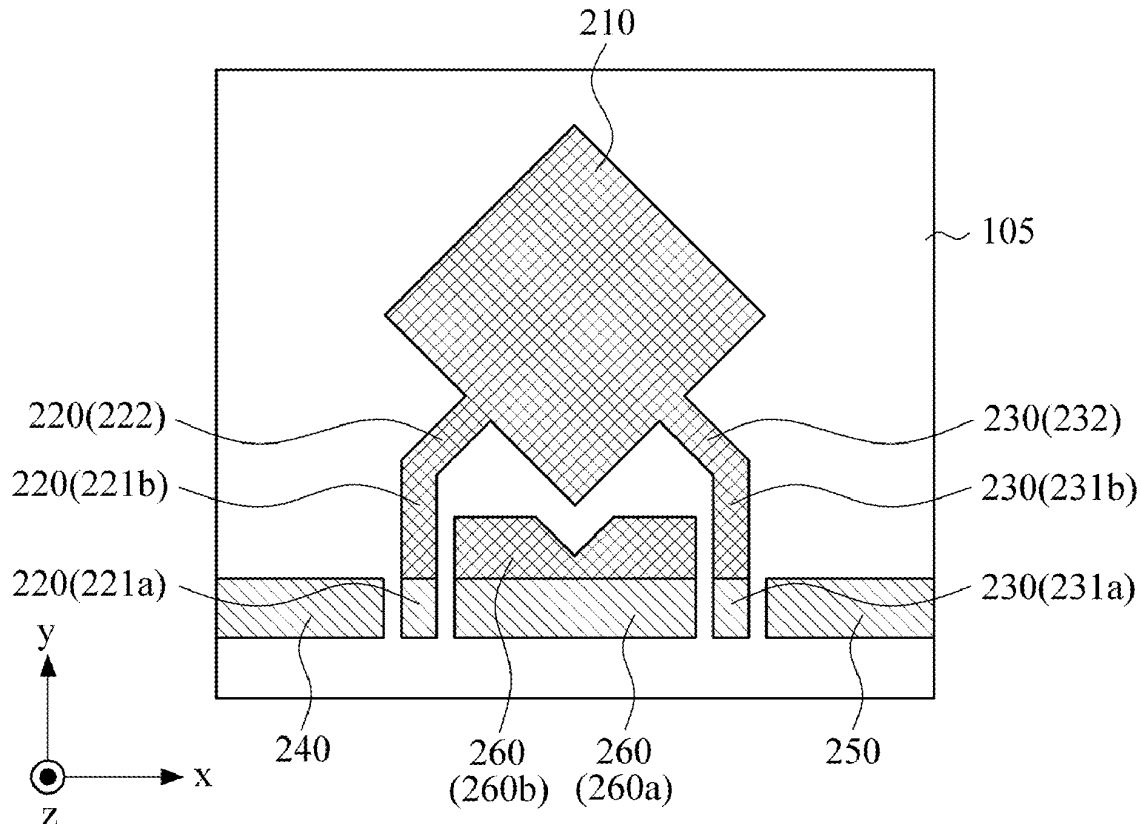



US 20250316902A1

(19) **United States**

(12) **Patent Application Publication**  
**YUAN**

(10) **Pub. No.: US 2025/0316902 A1**

(43) **Pub. Date: Oct. 9, 2025**

(54) **ELECTRONIC DEVICE AND COMMUNICATION SYSTEM**

**Publication Classification**

(71) Applicant: **GUANGDONG OPPO MOBILE TELECOMMUNICATIONS CORP., LTD.**, Dongguan (CN)

(51) **Int. Cl.**  
**H01Q 7/00** (2006.01)  
**H01Q 1/22** (2006.01)

(72) Inventor: **Qu YUAN**, Dongguan (CN)

(52) **U.S. Cl.**  
CPC ..... **H01Q 7/00** (2013.01); **H01Q 1/2258** (2013.01)

(73) Assignee: **GUANGDONG OPPO MOBILE TELECOMMUNICATIONS CORP., LTD.**, Dongguan (CN)

(57) **ABSTRACT**

(21) Appl. No.: **19/246,879**

An electronic device and a communication system are provided. The electronic device includes a ring-shaped functional conductor and a near field communication (NFC) antenna radiator. A hollowed-out region is surrounded by the functional conductor. The NFC antenna radiator is configured to transmit and receive a NFC signal at least toward a side where the functional conductor is located. An orthographic projection of the NFC antenna radiator on a plane where the functional conductor is located, is at least partially located within the hollowed-out region. The NFC antenna radiator is configured to be electrically connected to a radio frequency (RF) signal source and to generate a first electromagnetic field and a second electromagnetic field in opposite directions in the hollowed-out region under an excitation of the RF signal source, for enabling the functional conductor to generate a first induced current and a second induced current in opposite directions.

(22) Filed: **Jun. 24, 2025**

**Related U.S. Application Data**

(63) Continuation of application No. PCT/CN2023/135443, filed on Nov. 30, 2023.

(30) **Foreign Application Priority Data**

Mar. 2, 2023 (CN) ..... 202310195969.8

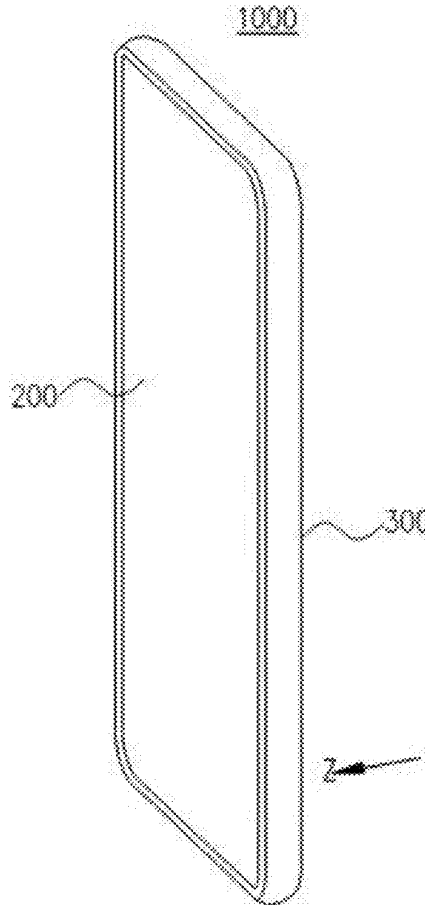



US 20250316903A1

(19) **United States**

(12) **Patent Application Publication**  
**Amjadi et al.**

(10) **Pub. No.: US 2025/0316903 A1**

(43) **Pub. Date: Oct. 9, 2025**

(54) **ELECTRONIC DEVICE WITH ANTENNA FOR RADIATING THROUGH REAR WALL**

(52) **U.S. Cl.**  
CPC ..... **H01Q 9/0414** (2013.01); **H01Q 1/22** (2013.01); **H01Q 1/48** (2013.01); **H01Q 9/0421** (2013.01)

(71) Applicant: **Apple Inc.**, Cupertino, CA (US)

(72) Inventors: **Seyed Mohammad Amjadi**, Santa Clara, CA (US); **Yiren Wang**, Cupertino, CA (US); **Hao Xu**, Cupertino, CA (US); **Sidharath Jain**, Redwood City, CA (US); **Cosan Caglayan**, San Mateo, CA (US); **Carlo Di Nallo**, Belmont, CA (US); **Mattia Pascolini**, San Francisco, CA (US)

(57) **ABSTRACT**

An electronic device may be provided with peripheral conductive housing structures, a rear wall, a first antenna, and a second antenna. The first antenna may have a resonating element formed from the peripheral conductive housing structures. The second antenna may have a folded antenna element overlapping the first antenna. The folded element may be disposed on at least three sides of a substrate. The folded element may follow a meandering path along at least two of the sides. A first end of the folded element may be coupled to a positive feed terminal. A second end of the folded element may be shorted to a conductive chassis. The folded element may exhibit minimum peak current magnitude at a surface of the substrate facing the rear wall, minimizing electromagnetic coupling between the first and second antennas and optimizing a radiation pattern of the second antenna through the rear wall.

(21) Appl. No.: **18/630,878**

(22) Filed: **Apr. 9, 2024**

**Publication Classification**

(51) **Int. Cl.**  
**H01Q 9/04** (2006.01)  
**H01Q 1/22** (2006.01)  
**H01Q 1/48** (2006.01)

